

DENSELIGHT SEMICONDUCTORS PTE. LTD.
6 Changi North St. 2, S498831 SINGAPORE
Tel: (65) 64154488
Fax: (65) 64157988
www.denselight.com

SPECIFICATIONS

1310 nm Edge-Emitting LED

DL-US3044E

DenseLight Semiconductors reserves the right to make product design or specifications changes without notice.

A. PRODUCT DESCRIPTION

The DenseLight DL-US3044E series is an uncooled edge emitting LED in TO-can packaged engineered for optical communication system and test instrument. It operates over a wide temperature range from 0 to 70°C without any needs for a thermoelectric cooler and temperature controller.

For responsive prototyping enquiries please email: info@denselight.com

B. FEATURES

- High coupled power
- Peak wavelength of 1310nm
- 3dB bandwidth of >40nm
- High speed >150MHz
- Operating temperature range 0 to 70°C
- TO-46 with flat window

C. APPLICATIONS

- Optical Communication system
- Optical Test Instrument
- Fiber Optic Sensors

D. ABSOLUTE MAXIMUM RATINGS

Parameter	Symbol	Condition	Min	Max	Unit
Reverse voltage	V_R			2	V
Forward current	I_F			150	mA
Forward voltage	V_F	I_{op}		2.5	V
Case temperature	T_C	I_{op}	0	70	°C
Storage temperature	T_{stg}	Unbiased	-40	85	°C
Electro static discharge (ESD)	V_{ESD}	Human body model		500	V
Lead soldering temperature	S_{temp}			260	°C
Lead soldering time	S_{time}			10	sec

E. SPECIFICATIONS ($T_c = 25\text{ }^\circ\text{C}$)

Parameter	Symbol	Condition	Min	Typ	Max	Unit
Operating current	I_{op}				100	mA
Forward voltage	V_F	I_{op}			2	V
Optical power	P_o	I_{op}	400			μW
Peak wavelength	λ_p	I_{op}	1280	1310	1330	nm
3dB Bandwidth	B_{FWHM}	I_{op}	40			nm
Cut off frequency	f_c	$I_{op} = 100\text{mA}$ $\pm 20\text{mA}_{p-p}$	150			MHz

F. PACKAGE

Pin Assignment	Description
1	LED Cathode
2	LED Anode
3	Case

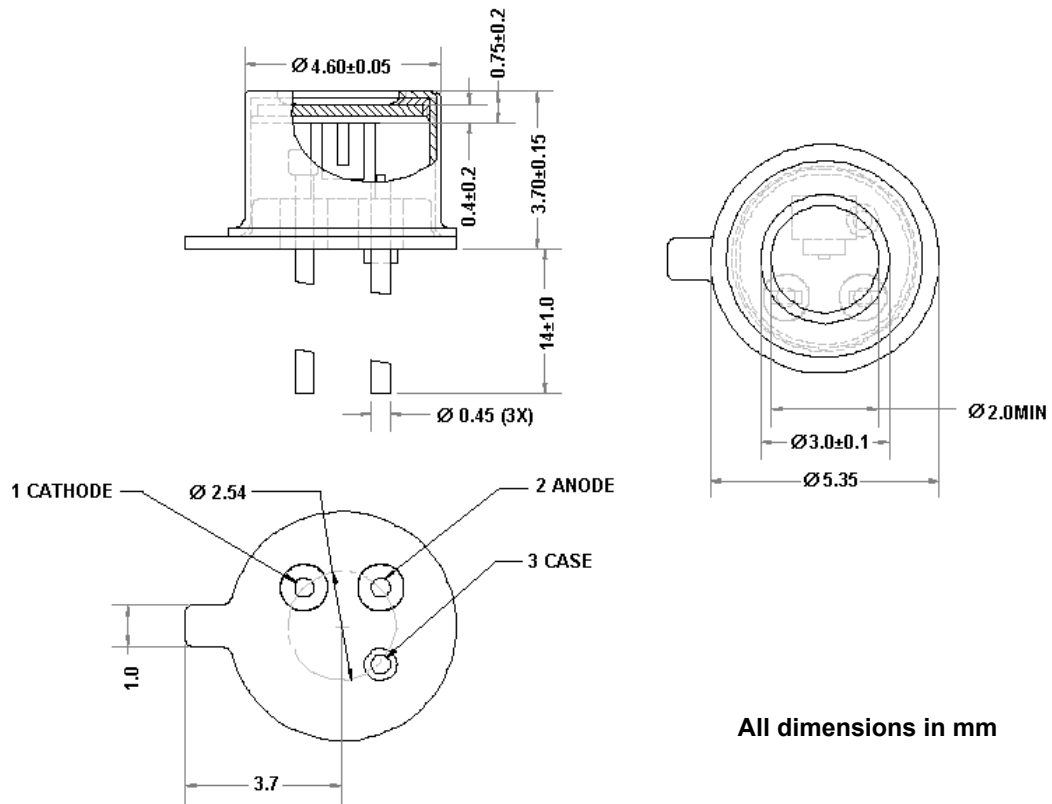

All dimensions in mm

G. TYPICAL PERFORMANCE CHARACTERISTICS

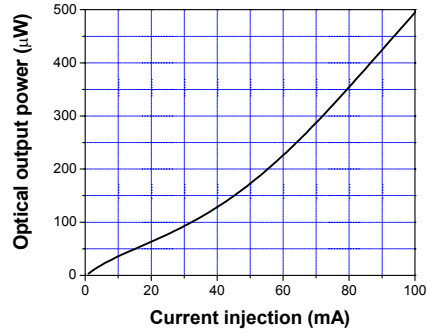

P-I Curve ($T_c=25\text{ }^\circ\text{C}$)

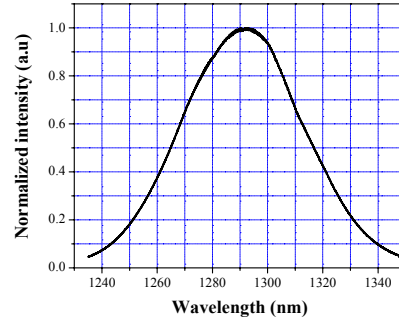

Spontaneous Emission Spectrum ($T_c=25\text{ }^\circ\text{C}$)

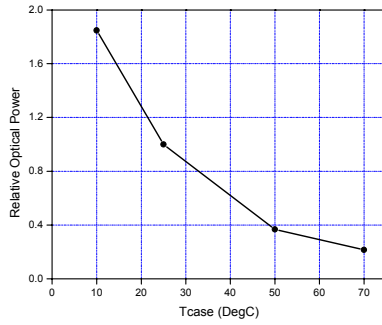

Temperature Dependence of Optical Power