

DENSELIGHT SEMICONDUCTORS PTE. LTD.  
6 Changi North St. 2, S498831 SINGAPORE  
Tel: (65) 64154488  
Fax: (65) 64157988  
[www.denselight.com](http://www.denselight.com)

## **SPECIFICATIONS**

### **1310 nm High Power Superluminescent LED**

#### **DL-CS3184B**

DenseLight Semiconductors reserves the right to make product design or specifications changes without notice.

## A. PRODUCT DESCRIPTION

The DenseLight DL-CS3184B series is a broadband SLED that operates in a true inherent superluminescent mode. This superluminescent property generates broader band at higher drive currents in contrast to other conventional SLEDs which are ASE-based, where high drive tends to give narrower band. Its low coherence reduces Rayleigh backscattering noise. Coupled with high power and large spectral width, it offsets photoreceiver noise and improves spatial resolution (in OCT) and measurand sensitivity (in sensors). The SLED is available in 14-pin DIL package. It is compliance with the requirements of Telcordia GR-468-CORE.

Enabled by DensePIC™ spread spectra bandgap engineering technology, future generations of DenseLight SLEDs promise higher chip powers (up to 50mW possible), and broader spectral bands (beyond 120nm). Higher levels of integration may feature integrated SLEDs with phase modulators, optical couplers and photodetectors into a complete optical sensor chipset.

For responsive prototyping enquiries please email: [info@denselight.com](mailto:info@denselight.com)

## B. FEATURES

- Typical ex-fiber output power of 20mW
- 3dB bandwidth of >40nm
- Typical spectral modulation of 0.15dB
- 14-pin DIL package
- Single mode fiber

## C. APPLICATIONS

- Fiber Optic Gyroscope
- Optical Test Instrument
- Fiber Optic Sensors
- Fiber Optic Communications
- Optical Coherence Tomography
- Biomedical Imaging Device
- Clinical Healing Equipment

## D. ABSOLUTE MAXIMUM RATINGS

Parameter	Symbol	Condition	Min	Max	Unit
Reverse voltage	$V_R$			2	V
Forward current	$I_F$			400	mA
Forward voltage	$V_F$	$I_{op}$		2.5	V
Case temperature	$T_c$	$I_{op}$	-40	65	°C
SLED temperature <sup>1</sup>	$T_{SLED}$	$I_{op}$	0	70	°C
Thermoelectric cooler voltage	$V_{TEC}$			3	V
Thermoelectric cooler current	$I_{TEC}$			1.8	A
Storage temperature	$T_{stg}$	Unbiased	-40	85	°C
Storage humidity			5	85	%RH
Electro static discharge (ESD)	$V_{ESD}$	Human body model		500	V
Lead soldering temperature	$S_{temp}$			260	°C
Lead soldering time	$S_{time}$			10	sec

## E. SPECIFICATIONS ( $T_{SLED} = 25\text{ °C}$ )

Parameter	Symbol	Condition	Min	Typ	Max	Unit
Operating current	$I_{op}$				350	mA
Forward voltage	$V_F$	$I_{op}$			2	V
Power in SMF	$P_o$	$I_{op}$	18	20		mW
Central wavelength	$\lambda$	$I_{op}$	1290	1310	1330	nm
Bandwidth	$B_{FWHM}$	$I_{op}$	40			nm
Spectrum modulation	R	$I_{op}$		0.15	0.35	dB
Thermistor resistance	$R_{therm}$	$T = 25\text{ °C}$	9.5	10	10.5	k $\Omega$
Thermoelectric cooler voltage	$V_{TEC}$	$I_{op}$			2.8	V
Thermoelectric cooler current	$I_{TEC}$	$I_{op}$			1.2	A

<sup>1</sup>  $T_{SLED}$  is monitored by internal thermistor with external pin out.

## F. PACKAGE

### DIL package

Part	Description
Package type	DIL
Fiber:	SMF-28 `
MFD	9 $\mu$ m
Cladding diameter	125 $\mu$ m
Coating diameter	245 $\mu$ m
Jacket	900 $\mu$ m loose tube
Fiber pigtail length	1m
Fiber bending radius	>40mm
Fiber Connector	FC/APC
Dimensions	See figure

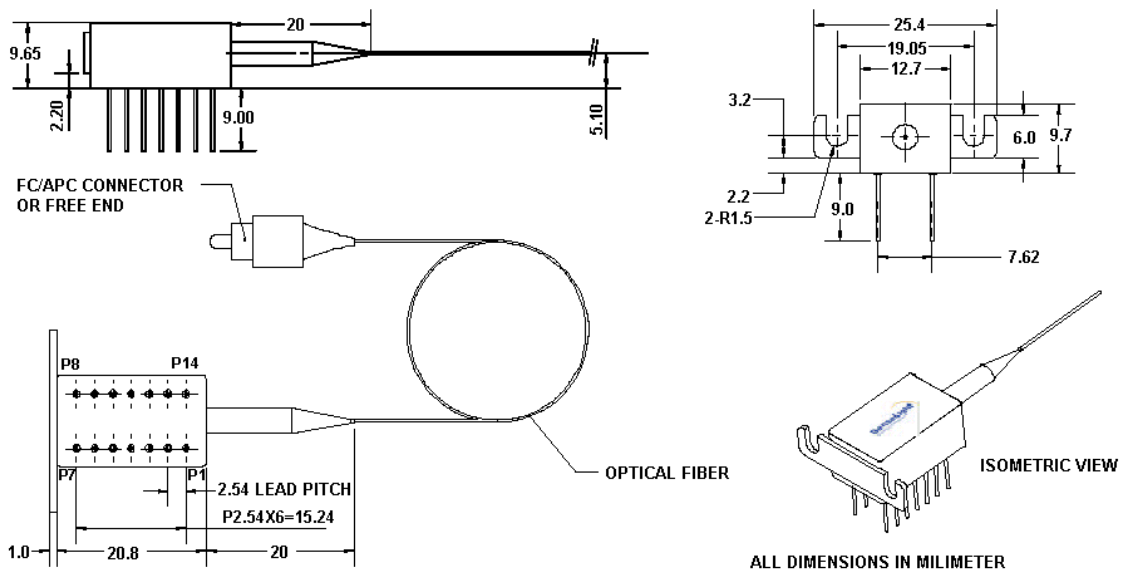

Pin Assignment	
1	TEC+
2	--
3	--
4	--
5	SLED ANODE +
6	--
7	--
8	--
9	SLED CATHODE -
10	SLED ANODE +
11	THERMISTOR
12	THERMISTOR
13	CASE
14	TEC -

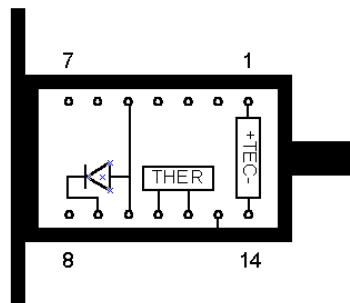

## G. TYPICAL PERFORMANCE CHARACTERISTICS

Operating condition:  $T_{SLED} = 25\text{ }^{\circ}\text{C}$

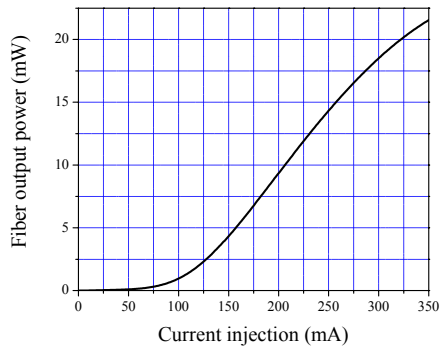

**P-I Curve**

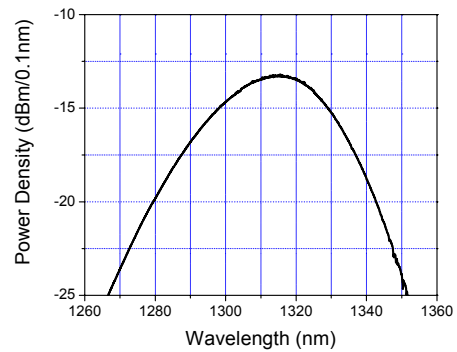

**Spontaneous Emission Spectrum**

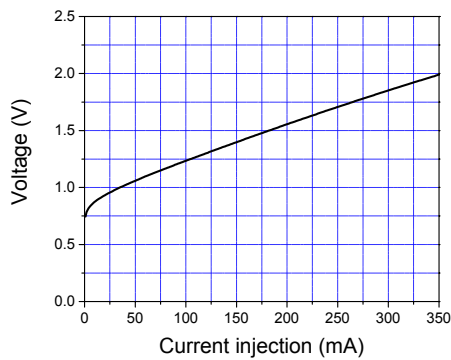

**I-V Curve**

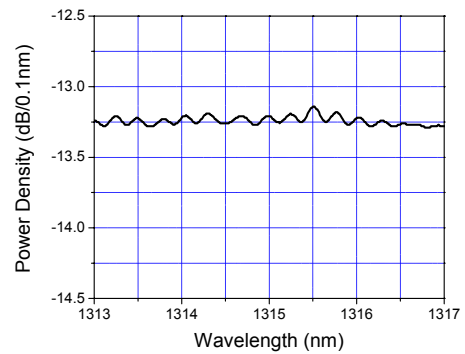

**Spectrum Modulation**