

DENSELIGHT SEMICONDUCTORS PTE. LTD.
6 Changi North St. 2, S498831 SINGAPORE
Tel: (65) 64154488
Fax: (65) 64157988
www.denselight.com

SPECIFICATIONS

1650 nm Superluminescent LED

DL-CS65L9A

DenseLight Semiconductors reserves the right to make product design or specifications changes without notice.

A. PRODUCT DESCRIPTION

The DenseLight DL-CS65L9A series is a broadband SLED that operates in a true inherent superluminescent mode. This superluminescent property generates broader band at higher drive currents in contrast to other conventional SLEDs which are ASE-based, where high drive tends to give narrower band. Its low coherence reduces Rayleigh backscattering noise. Coupled with high power and large spectral width, it offsets photoreceiver noise and improves spatial resolution (in OCT) and measurand sensitivity (in sensors). The SLED is available in 14-pin BTF package. It is compliance with the requirements of Bellcore Document GR-468-CORE.

Enabled by DensePIC™ spread spectra bandgap engineering technology, future generations of DenseLight SLEDs promise higher chip powers (up to 50mW possible), and broader spectral bands (beyond 120nm). Higher levels of integration may feature integrated SLEDs with phase modulators, optical couplers and photodetectors into a complete optical sensor chipset.

For responsive prototyping enquiries please email: info@denselight.com

B. FEATURES

- Ex-fiber output power of >2mW
- 3dB bandwidth of >80nm
- Typical spectral modulation of 0.1dB
- 14-pin BTF package
- Single mode fiber

C. APPLICATIONS

- Fiber Optic Gyroscope
- Optical Test Instrument
- Fiber Optic Sensors
- Fiber Optic Communications
- Optical Coherence Tomography
- Biomedical Imaging Device
- Clinical Healing Equipment

D. ABSOLUTE MAXIMUM RATINGS

| Parameter | Symbol | Condition | Min | Max | Unit |
|--------------------------------|------------|------------------|-----|-----|------|
| Reverse voltage | V_R | | | 2 | V |
| Forward current | I_F | | | 350 | mA |
| Forward voltage | V_F | I_{op} | | 2.5 | V |
| Case temperature | T_C | I_{op} | -40 | 70 | °C |
| SLED temperature ¹ | T_{SLED} | I_{op} | 0 | 70 | °C |
| Thermoelectric cooler voltage | V_{TEC} | | | 3.0 | V |
| Thermoelectric cooler current | I_{TEC} | | | 1.8 | A |
| Storage temperature | T_{stg} | Unbiased | -40 | 85 | °C |
| Storage humidity | | | 5 | 85 | %RH |
| Electro static discharge (ESD) | V_{ESD} | Human body model | | 500 | V |
| Lead soldering temperature | S_{temp} | | | 260 | °C |
| Lead soldering time | S_{time} | | | 10 | sec |

E. SPECIFICATIONS ($T_{SLED} = 25\text{ °C}$)

| Parameter | Symbol | Condition | Min | Typ | Max | Unit |
|-------------------------------|-------------|--------------------|------|------|------|------------|
| Operating current | I_{op} | | | | 300 | mA |
| Forward voltage | V_F | I_{op} | | | 2 | V |
| Power in SMF | P_o | I_{op} | 2 | | | mW |
| Central wavelength | λ | I_{op} | 1630 | 1650 | 1670 | nm |
| Bandwidth | B_{FWHM} | I_{op} | 80 | | | nm |
| Spectrum modulation | R | I_{op} | | 0.1 | 0.2 | dB |
| Thermistor resistance | R_{therm} | $T = 25\text{ °C}$ | 9.5 | 10 | 10.5 | k Ω |
| Thermoelectric cooler voltage | V_{TEC} | I_{op} | | | 2.5 | V |
| Thermoelectric cooler current | I_{TEC} | I_{op} | | | 1.1 | A |

¹ T_{SLED} is monitored by internal thermistor with external pin out.

F. PACKAGE

BTF package

| Part | Description |
|----------------------|------------------------|
| Package type | BTF |
| Fiber: | SMF-28 |
| MFD | 10 μ m |
| Cladding diameter | 125 μ m |
| Coating diameter | 245 μ m |
| Jacket | 900 μ m loose tube |
| Fiber pigtail length | 1m |
| Fiber bending radius | >40mm |
| Connector | FC/APC |
| Dimensions | See figure |

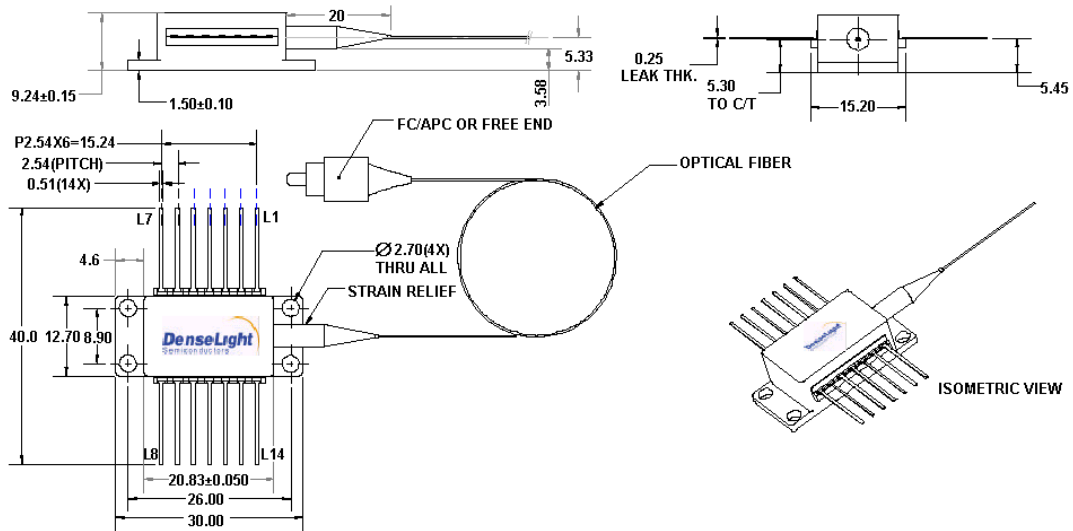

| Pin Assignment | |
|----------------|----------------|
| 1 | TEC+ |
| 2 | THERMISTOR |
| 3 | - |
| 4 | - |
| 5 | THERMISTOR |
| 6 | - |
| 7 | - |
| 8 | - |
| 9 | - |
| 10 | SLED ANODE + |
| 11 | SLED CATHODE - |
| 12 | - |
| 13 | CASE |
| 14 | TEC - |

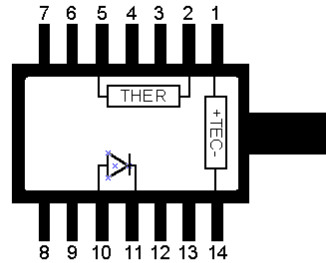

G. TYPICAL PERFORMANCE CHARACTERISTICS

Operating condition: $T_{SLED} = 25\text{ }^{\circ}\text{C}$

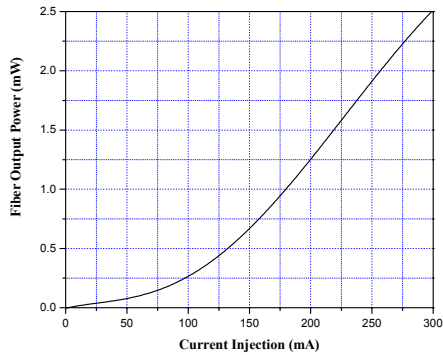

P-I Curve

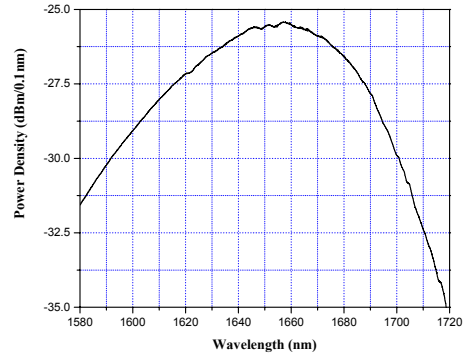

Spontaneous Emission Spectrum

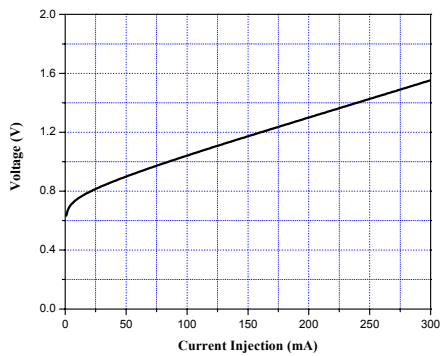

I-V Curve

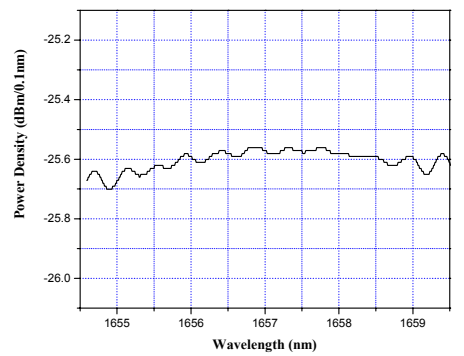

Spectrum Modulation

**The unevenness on the spectral emission spectrum is caused by the limitation of the OSA Spectrum analyzer at those wavelengths.*