

In-line Polarizer (DL-ILP-VV-W-X-Y-Z)

The In-line Polarizer can be used to pass light with one specific polarization while blocking the other polarization. Unpolarized light can also be converted into polarized light with high extinction ratio. It is ideal for high speed communication systems and test instrumentations where high polarization extinction ratio is required.

A. Specifications

Parameters	Values	Unit
Center Wavelength (λ_c)	1310, 1480 or 1550	nm
Operating Wavelength Range	$\lambda_c \pm 50$	nm
Max. Insertion Loss, 23 °C	0.5	dB
Min. Extinction Ratio, 23 °C	28	dB
Max. Optical Power (Continuous Wave)	300	mW
Min. Return Loss	50	dB
Operating Temperature	-5 to +70	°C
Storage Temperature	-40 to +85	°C

*IL is 0.3 dB higher, RL is 5 dB lower, and ER is 2 dB lower for each connector added. Connector key is aligned to slow axis.

B. Package Dimensions

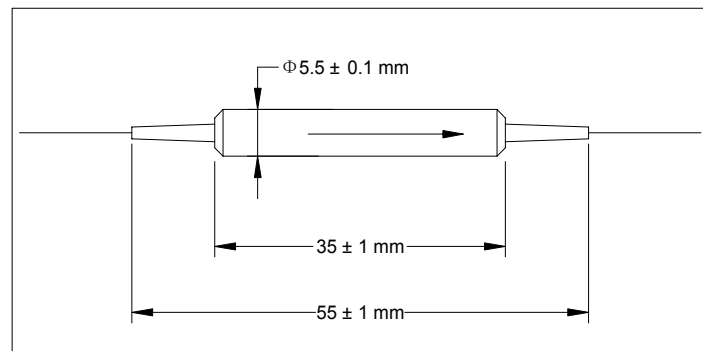

C. Ordering Information

DL-ILP-VV-W-X-Y-Z

VV: Wavelength	W: Connector Type	X: Fiber Type	Y: Fiber Type (Input/Output)	Z: Fiber Length
31 - 1310 nm	1 - FC/UPC	B - 250 μ m Panda fiber	1 - PM/PM	
48 - 1480 nm	2 - FC/APC	D - 400 μ m Panda fiber	2 - SMF/PM	
55 - 1550 nm	3 - SC/UPC	L - 900 μ m loose tube	3 - SMF/SMF	Q - 0.75 m
SS - Specify	4 - SC/APC	S - Specify		S - Specify
	N - None			