

**DENSELIGHT SEMICONDUCTORS PTE. LTD.**  
6 Changi North St. 2, S498831 SINGAPORE  
[sales@denselight.com](mailto:sales@denselight.com)  
[www.denselight.com](http://www.denselight.com)

## **1550nm Medium Power Optical Source**

**DL-CS55057C-FP-PD-T30**

DenseLight Semiconductors reserves the right to make product design or specifications changes without notice.

---

## A. PRODUCT DESCRIPTION

The DenseLight DL-CS55057C-FP-PD-T30 is a 1550nm medium power optical source that is qualified for operating case temperature range of -20°C to 60°C when SLED chip temperature is 25°C and certified for -30°C to 71°C when SLED chip temperature is 30°C. The broadband source is packaged in an 8-pin BTF footprint integrated with monitoring photodiode with polarization maintaining fiber output.

For responsive prototyping enquiries please email: [sales@denselight.com](mailto:sales@denselight.com)

## B. FEATURES

- Ex-fiber output power of >5mW at case temperature 25°C
- 3dB bandwidth of > 45nm
- Spectral ripple of <0.4dB
- Case temperature of -30 to +71 °C
- 8-pin BTF package
- Integrated Photodiode
- Polarization maintaining fiber

## C. APPLICATIONS

- Fiber Optic Gyroscope
- Optical Test Instrument
- Fiber Optic Sensors
- Fiber Optic Communications
- Optical Coherence Tomography
- Biomedical Imaging Device
- Clinical Healing Equipment

---

DenseLight Semiconductors reserves the right to make product design or specifications changes without notice.

## D. ABSOLUTE MAXIMUM RATINGS

Stresses beyond the absolute maximum ratings may cause permanent damage to the device. Exposure to absolute maximum rating conditions for extended periods may affect device reliability.

Parameter	Symbol	Condition	Min	Max	Unit
Reverse voltage	$V_R$			2	V
Forward current	$I_F$			350	mA
Forward voltage	$V_F$	$I_{op}$		2.4	V
Case temperature	$T_C$	$I_{op}$	-30	71	°C
Thermoelectric cooler voltage	$V_{TEC}$			3.2	V
Thermoelectric cooler current	$I_{TEC}$			1.8	A
Storage temperature	$T_{stg}$	Unbiased	-40	85	°C
Storage humidity			5	85	%RH
Electro static discharge (ESD)	$V_{ESD}$	Human body model		500	V
Lead soldering temperature	$S_{temp}$			260	°C
Lead soldering time	$S_{time}$			10	sec

## E. SPECIFICATIONS ( $T_{SLED}^{(1)} = 30\text{ °C}$ )

Parameter	Symbol	Condition	Min	Typ	Max	Unit
Operating current	$I_{op}$				275	mA
Power in PM	$P_o$	$I_{op}$	5			mW
Central wavelength	$\lambda$	$P_o$	1535	1550	1565	nm
Bandwidth	$B_{FWHM}$	$I_{op}$	45	50		nm
Spectrum modulation	R	$I_{op}$			0.4	dB
Thermistor resistance	$R_{therm}$	$T_{SLED} = 30\text{ °C}$	7.5	8	8.5	K $\Omega$
Photodiode monitoring current		$I_{op}$	100			$\mu$ A
Polarization extinction ratio	PER	$I_{op}$	12			dB

- Short term power stability @  $\pm 0.1$ dB (1Hour)
- Thermistor characteristic over temperature will be provided

(1)  $T_{SLED}$  is monitored by internal thermistor with external pin out.

DenseLight Semiconductors reserves the right to make product design or specifications changes without notice.

## F. PACKAGE

### 8-PIN BTF package

Part	Description
Package type	8-Pin BTF
Fiber:	Panda PMF
MFD	10.5 $\mu$ m
Cladding diameter	125 $\mu$ m
Coating diameter	245 $\mu$ m
Fiber pigtail length	>1.2m
Fiber bending radius	>40mm
Connector	FC/APC
Dimensions	See figure

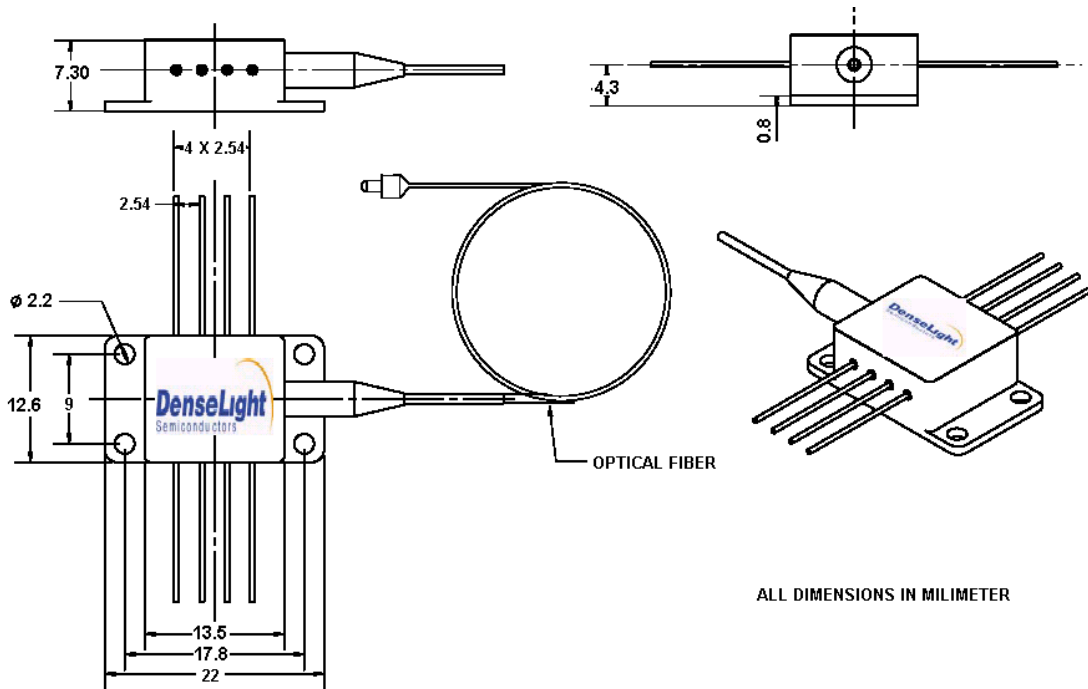

Pin Assignment	
1	TEC (+)
2	THERMISTOR
3	THERMISTOR
4	DIODE ANODE (+)
5	DIODE CATHODE (-)
6	PD CATHODE (+)
7	PD ANODE (-)
8	TEC (-)

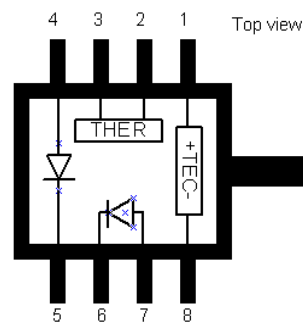

DenseLight Semiconductors reserves the right to make product design or specifications changes without notice.